

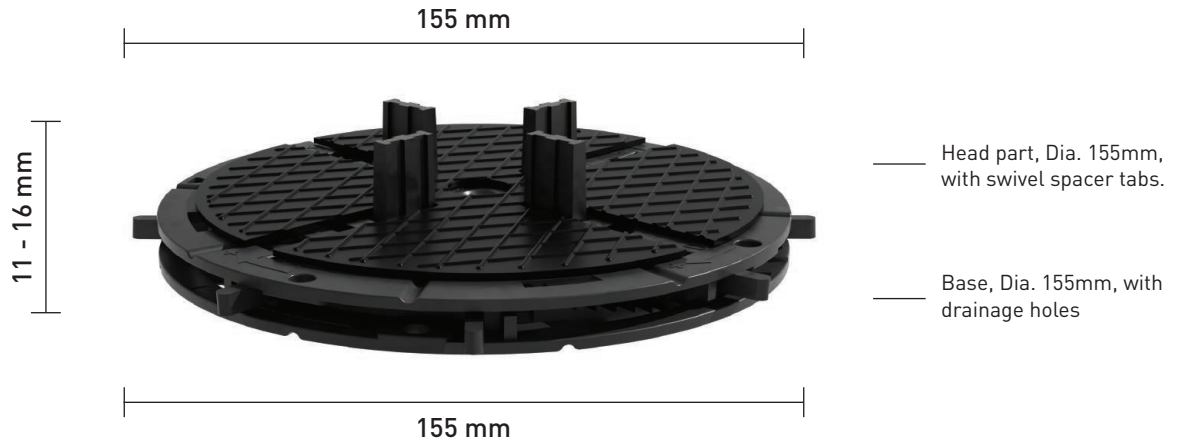

pbp-a

Adjustable paver pedestal



ADJUSTABLE HEIGHT

Adjustable height from 11mm to 16mm uninterrupted

COMPOSITION

1 head + 1 base + 1 spacer tab + 1 shim

MATERIAL

Polypropylene (PP), material thickness 4.5 - 6mm;
Composition 90% PP, 10% talc, UV and black masterbatch
100% recyclable.

DIMENSIONS

Head = diameter 155mm - surface area 188cm²
Base = diameter 155mm - ground surface 188cm²
Extender = extender diameter 120mm - adjustable height

PERFORMANCE

Resisting UV rays, weather, sea salt & almost all chemicals.
Temperature range: -40°C to +120°C.

APPLICATION

Support for outdoor terraces with any kind of material:
timber decking, stone, ceramic, composite material, metal,
fibreglass grid... Can be placed on any stable substrate,
also over insulation panels.

SLOPE CORRECTOR FROM 0% - 5%

Slope correctors could compensate ground fall 0% - 5%,
making an ideal level surface. It is assembled on the
bottom of pedestals. Clients could choose to use it or not
with different installation conditions.



3A Bellfrog Street Greenacre NSW 2190
www.polybit.com.au



FIRE RATED
WILL NOT IGNITE



INTERNATIONALLY
TESTED & PROVEN



10 YEAR
MANUFACTURERS WARRANTY



pbp-a

Adjustable paver pedestal

APPLICATION DETAILS

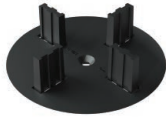

1. Spacer tab thickness: 2mm, 3.5mm, 5mm, 8mm, 10mm



2. Slope corrector: slope compensation of 0% - 5%



1 mm / 2 mm thickness

3. Shim: anti-slip, reduced impact, absorb shock and sound, compensate for a difference in floor thickness



Made in PP

4. Fix Collar: Fix and lock height after adjustment, increases stability.



COMPRESSION TEST

Performed on the full (1/1), half (1/2) or quarter (1/4) surface of the head

Position	Height (mm)	Breaking Loads (kgs)
1/1	17	1350
1/2	17	1162
1/4	17	982

Safety Value for maximum allowable load by compression for PBP-A:

1. Safety for pedestrian terrace: divide the load indicated in the table by 2 with a safety factor of -15%.
2. Safety for technical floors: divide the load indicated in the table by 4 with a safety factor of -15%.

DISCLAIMER

The information, and, in particular, the recommendations relating to the application and end-use of Polybit Waterproofing Systems products, are given in good faith based on Polybit Waterproofing Systems current knowledge and experience of the products when properly stored, handled and applied under normal conditions.

It is your responsibility to ensure that our products meet your requirements, are used and handled correctly in accordance with any applicable Australian Standard, our instructions and recommendations and only used for the applications for which they are intended.

In practice, the differences in materials, substrates and actual site conditions are such that no warranty in respect of merchantability or of fitness for a particular purpose, nor any liability arising out of any legal relationship whatsoever, can be inferred either from this information, or from any written recommendations, or from any other advice offered.

We also reserve the right to update information without prior notice to you to reflect our ongoing research and development.

The supply of our products and services is also subject to certain terms, warranties and exclusions, which may have been disclosed to you in prior dealings or are otherwise available to you on request. You should make yourself familiar with these.



3A Bellfrog Street Greenacre NSW 2190
www.polybit.com.au



FIRE RATED
WILL NOT IGNITE

